

College Gardens Apartments: Water Savings at Affordable Housing Units

*College Gardens Apartments:
saving more than one million
gallons of water and
reducing water costs*

Case Study Highlights

Company: College Gardens
Apartments
Dania Beach, Florida

Problems:

- High monthly water usage and costs
- Staff time required to fix toilet issues

Solution: 48 Caroma
Sydney 270 Easy
Height Elongated
High Efficiency Toilets

Benefits:

- Average monthly water usage reduced by 122,000 gallons or 45% less water used
- Average water cost reduced by more than \$747/month (a 30% cost savings)
- Blockages and overflows eliminated
- Positive tenant feedback



Dania Beach, Florida is a quaint, seaside town conveniently located between Ft. Lauderdale and Miami. You can relax in the sun on the isolated, sandy beaches surrounded by shade coconut palms or visit the downtown with a selection of antique shops, art galleries, cafes, casual and fine dining. Dania Beach has something for everyone.

In South Florida, 90 percent of the water used in homes and businesses comes from groundwater sources, which is replenished by rainfall. Even though Florida is one of the wettest states, much of the water is lost through evaporation. South Florida, like many regions, is experiencing population growth combined with multi-year droughts. This has led cities and governments to implement water conservation programs and suggest techniques for conserving water to address the long term needs of the region.

It is estimated that 40% of the water used in a home is used by toilets. Homes built in the 1950s and 1960s often had toilets using seven gallons or more of water per flush. By the 1980s, technology had improved to use 3.5 gallons per flush. In 1995, a 1.6 gallon or less toilet was mandated in all states in the United States. Toilet technology has advanced considerably in the last 20 years, and now the average household can save thousands of gallons of water in just one year.

Water savings at College Gardens Apartments

Located in Dania Beach, College Gardens Apartments is a complex with more than 60 affordable housing units. During late 2008, Caroma toilets were installed in three buildings, including 24 three bedroom, two bathroom units to help conserve water in the region. Two models of the Sydney range high efficiency dual flush toilets were chosen (Sydney 270 Easy Height Elongated and 305 model Round Front Plus).

Caroma toilets were selected for College Gardens Apartments for three reasons: water conservation to protect the environment, to

reduce water bills, and lower maintenance costs. Prior to the Caroma installation, some apartments had 3.5 gallon per flush toilets, 2.5 gallon per flush, and 1.6 gallon per flush toilets.

The Sydney toilet range is a two button dual flush: one button using 1.6 gallons per flush for solid waste and one button using 0.8 gallons per flush for liquid and paper waste. The average flush volume is only 0.96 gallons per flush, saving 40% more water compared to the federal mandate of 1.6 gallons, 62% more water than a 2.5 gallon toilet, and more than 72% water savings compared to a 3.5 gallon toilet.

The water savings in College Gardens Apartments have been impressive. 16 units had toilets installed during October and November 2008, and the remaining 8 were completed in December. Graph 1 displays the water usage and costs from mid-April 2008 – mid-April 2009 for the 24 units.

During the first six month period recorded, the average water usage was 272,167 gallons and costs \$2452 per month. The following six month period during and after the Caroma installation was completed, there was a 45%

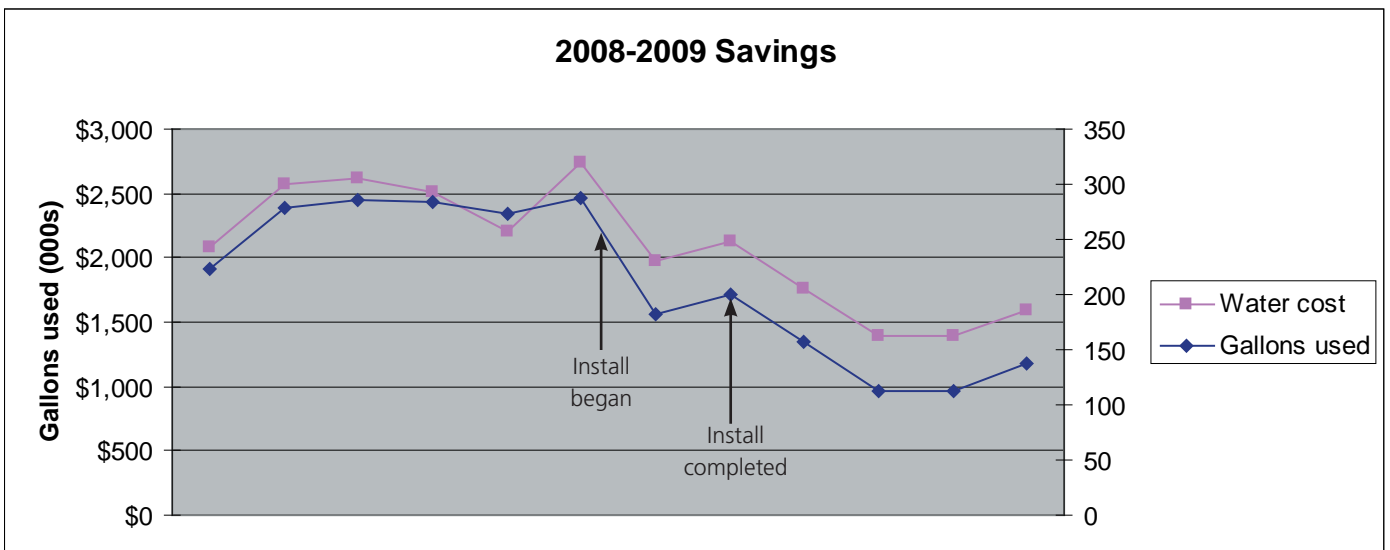

Graph 1: Water and cost savings using Caroma toilets at College Gardens Apartments

reduction in water usage. The average water rate was 150,667 gallons, averaging \$1704 per month. This equates to an average of 121,500 gallons in water savings per month (more than 1.46 million gallons per year) and nearly \$9000 in yearly cost savings!

In addition to water and cost savings, Caroma toilets also reduce maintenance expenses. The two piece Sydney toilets have a large trapway, nearly double the industry average. This virtually eliminates clogging. In the six months the toilets have been installed at College Gardens Apartments, there have been no calls to maintenance due to overflows or clogging. Because the toilets use wash down technology, waste is pushed from the bowl, creating greater drainline carry, minimizing the chance of blockages further down the pipe.

All Caroma floor-mount toilets are WaterSense labeled. WaterSense is a partnership program sponsored by the U.S Environmental Protection Agency to label products that meet both water savings and quality criteria. The Sydney range used at College Gardens has met the criteria of this program.

Tenants have also benefited from the Caroma toilets. The stylish toilets (see Image 1) have clean lines, so cleaning is very easy. Because the toilets do not clog, they do not need an unsightly plunger nearby. The best part: they are helping to substantially reduce the amount of indoor water usage with every push of the Sydney dual flush toilet button.



Image 1: Sydney installation at College Gardens Apartments

2009 changes

During 2009, Caroma will be replacing the Sydney range of high efficiency toilets with Sydney Smart HETs, providing even greater water savings. The dual flush Sydney Smart range uses 1.28 gallons per flush for a full flush and 0.8 gallons per flush for half flush, averaging only 0.9 gallons per flush. The Sydney Smart range includes six bowl configurations and is available in white and biscuit.

Sydney 270 Easy Height Elongated



Contemporary style, advanced performance

- High efficiency toilet (HET) - 1.6/0.8 gallons (6/3 liters) per flush
- Two piece, two button dual flush toilet
- 17" high elongated bowl
- Large fully concealed trapway
- Virtually unblockable
- 10-12" adjustable rough-in
- WaterSense labeled

Dimensions

31 1/4" L x 18 3/4" W x 33 7/8" H (bowl height = 17")

Sydney 270 also available in Round Front Plus, Easy Height Round Front Plus, and Elongated.

Sydney 270 Easy Height Elongated

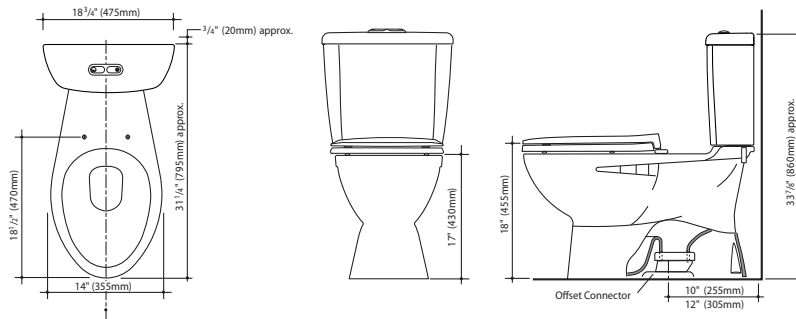

Additional information available

Caroma
 Phone: +1 800 605 4218
 Fax: +1 503 681 2150
 Email: info@caromausa.com
 Website: www.caromausa.com

